



## SECTION 7D

# AUTOMATIC TEMPERATURE CONTROL HEATING, VENTILATION, AND AIR CONDITIONING SYSTEM

**Caution :** Disconnect the negative battery cable before removing or installing any electrical unit or when a tool or equipment could easily come in contact with exposed electrical terminals. Disconnecting this cable will help prevent personal injury and damage to the vehicle. The ignition must also be in LOCK unless otherwise noted.

## SPECIFICATIONS

### Fastener Tightening Specifications

Application	N·m	Lb-Ft	Lb-In
Air Filter Cover Nut	4	-	35
Ambient Air Temperature Retaining Bracket Nut	6	-	53
Blower Motor Resistor Screws	6	-	53
Control Assembly Retaining Screws	2.5	-	22
Expansion Valve Bolts	10	-	89
Heater/Air Distributor Assembly Case Screws	8	-	71
Liquid Evaporator Pipe Retaining Nuts	10	-	89
Suction Hose Retaining Nuts	10	-	89

## SCHEMATIC AND ROUTING DIAGRAMS

### A/C Sensors and Defoggers Diagram

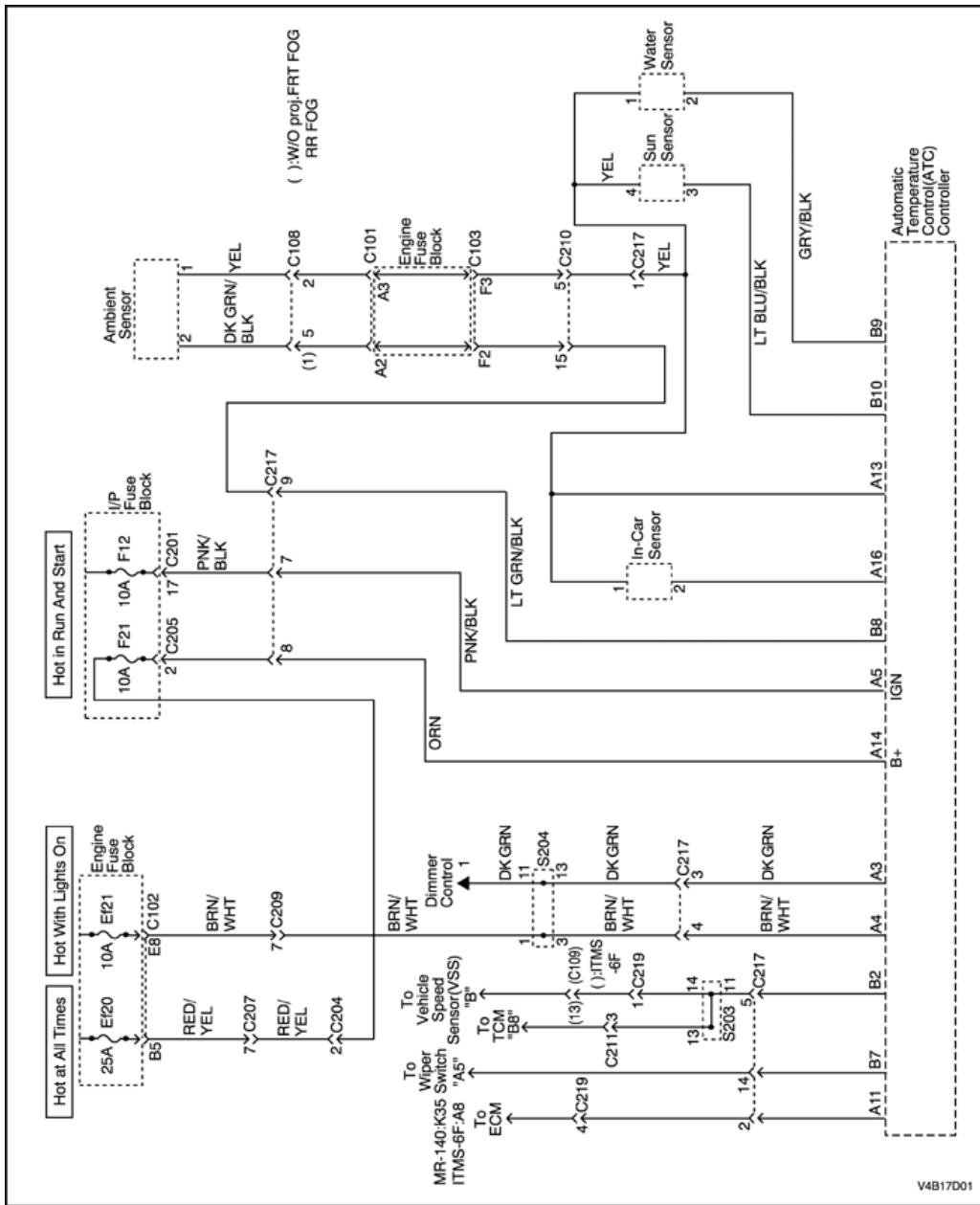

A/C Blower and Motor Controls Diagram

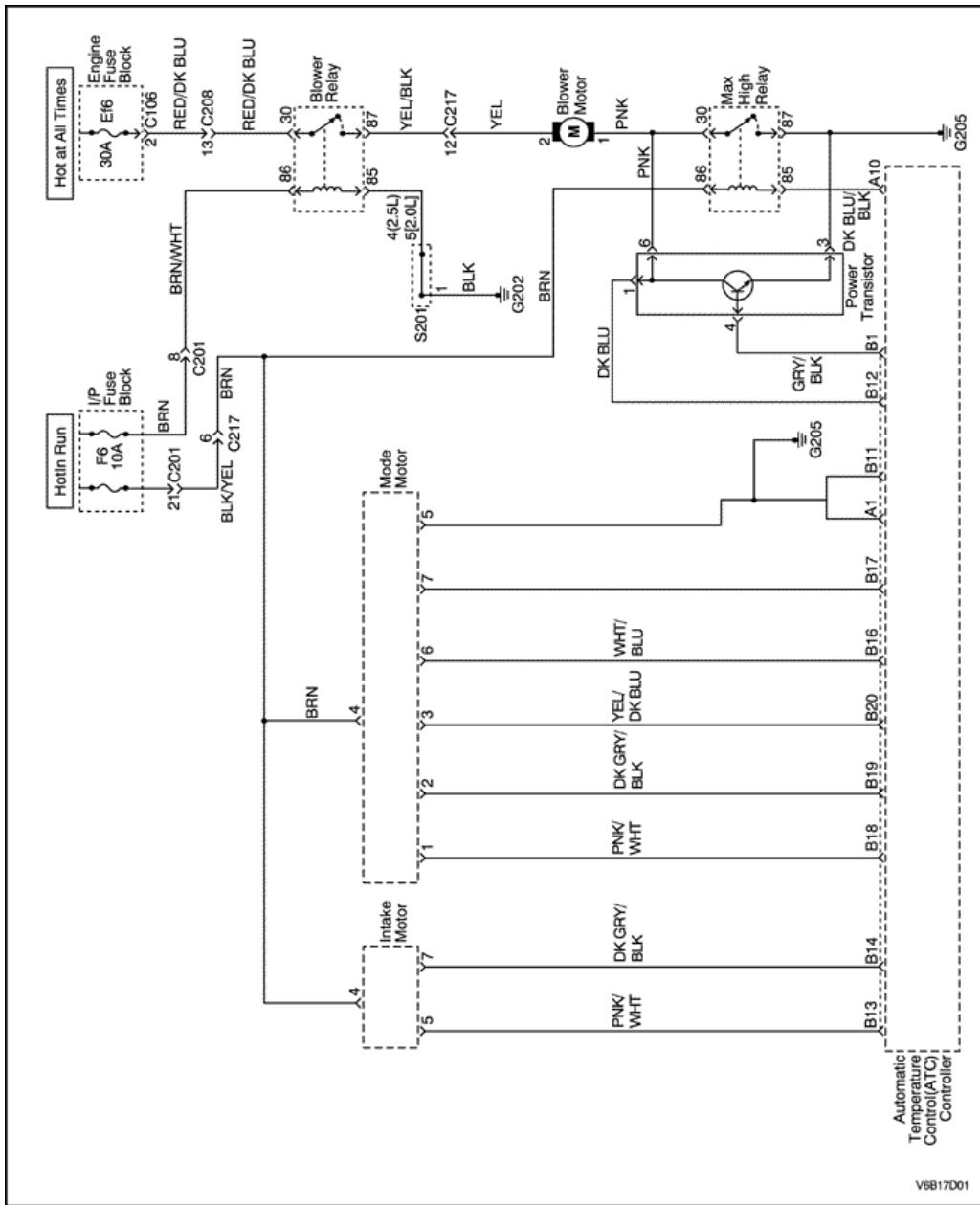

A/C Compressor Controls Diagram

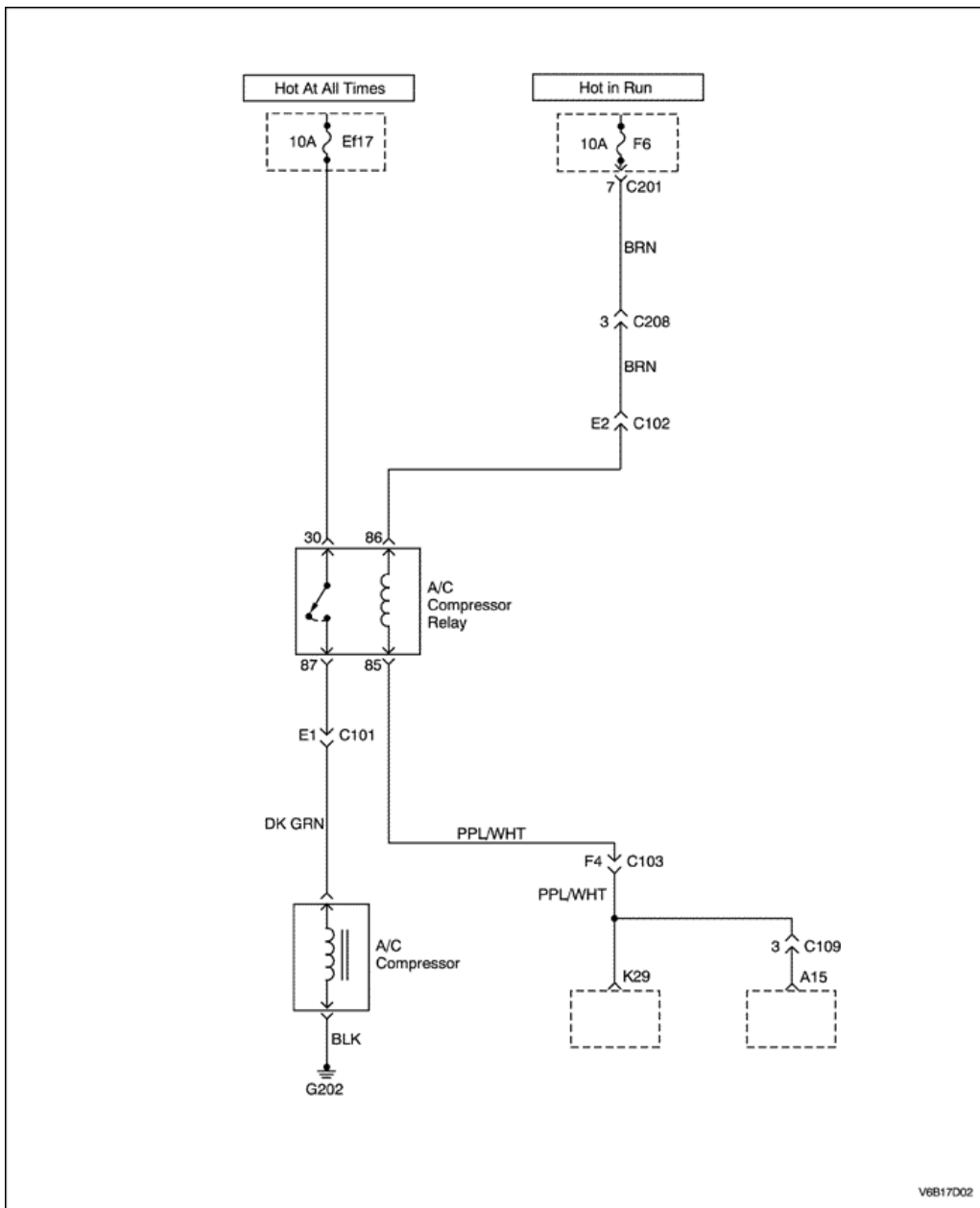

## DIAGNOSIS

### General A/C Diagnostics

Refer to [Section 7B, Manual Control Heating, Ventilation, and Air Conditioning System](#) for details of the following procedures:

- A/C Performance Test.
- Insufficient Cooling "Quick Check" Procedure.
- Insufficient Cooling Diagnosis.
- Leak Testing the Refrigerant System.
- Low- and High-Side Pressure Relationship Chart.
- Pressure Test Chart (R-134a System).
- Pressure-Temperature Relationship of R-134a.
- Testing the Refrigerant System.

### V5 SYSTEM AIR CONDITIONING AND AUTOMATIC TEMPERATURE CONTROL (ATC)

#### Self-Diagnostic Circuit Check

The Daewoo fully automatic temperature controller (FATC) contains a self-diagnosis function to aid in finding any problem with the system. To enter the diagnostic mode, perform the following procedure:

1. Turn the ignition to ON.
2. Set the temperature control to 26°C (79°F).
3. Within 3 seconds, push the AUTO and the OFF switches simultaneously, more than three times.
4. Count the number of times the temperature indicator screen blinks.

5. If there are no error codes set, the screen will not blink. When the controller indicates an error code, proceed to the table for that code.
6. Push the OFF switch to return the controller to its normal functions.

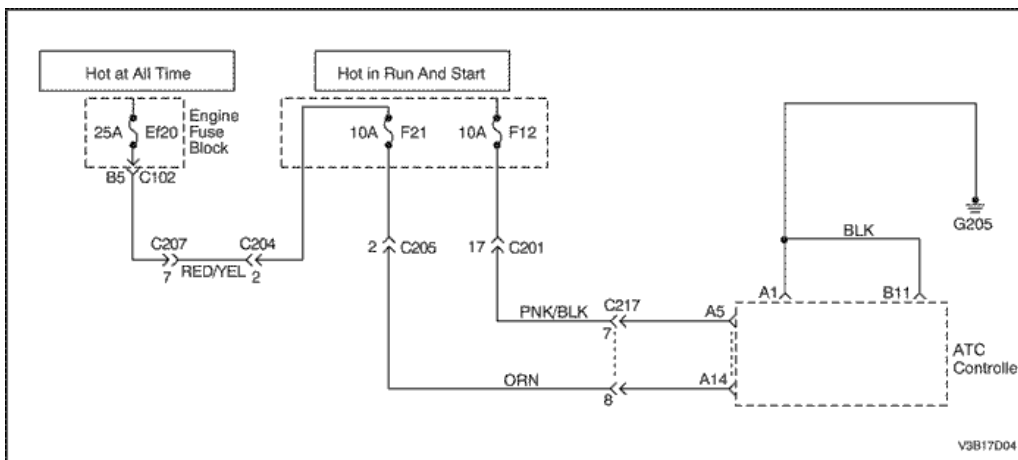

### Automatic Temperature Controller Does Not Operate When Ignition Is ON

Step	Action	Value(s)	Yes	No
1	Check the fuse F12. Is fuse F12 blown?	-	Go to Step 2	Go to Step 3
2	Replace fuse F12. Is the repair complete?	-	System OK	-
3	1. Remove the controller. 2. Measure the voltage between connectors A5 and A14. Is the voltage within the specified value?	11-14 v	Go to Step 4	Go to Step 5
4	1. Check the controller for damage. 2. Replace the controller if it is damaged. Is the repair complete?	-	System OK	-
5	Check the voltage between terminal A1 and ground. Is this voltage as specified?	0 v	Go to Step 6	Go to Step 7
6	1. Check the wiring harness between fuse F12 and the terminal A5 for damage. 2. Replace the wiring harness if it is damaged. Is the repair complete?	-	System OK	-
7	1. Check the wiring harness between terminal A14 and ground G205 for damage. 2. Repair the wiring harness, or ground connection as required. Is the repair complete?	-	System OK	-

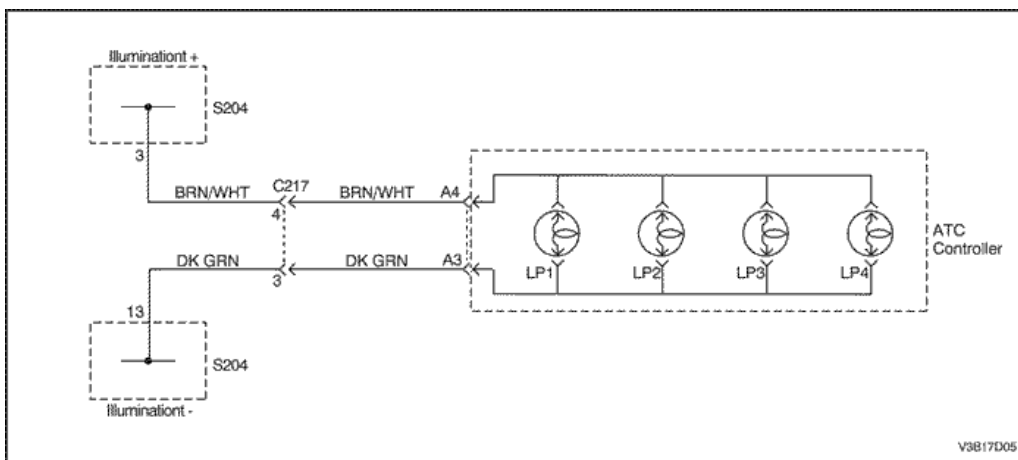

### Controller Does Not Illuminate When Light Switch Is ON

Step	Action	Value(s)	Yes	No
1	Check other instrumentation lights. Are those lights also off?	-	Go to <a href="#">Section 9E, Instrumentation/Driver Information</a>	Go to Step 2
2	1. Remove the controller. 2. Check the voltage between terminals A3 and A4 of the controller connector.  Is the voltage within the specified value?	11-14 v	Go to Step 4	Go to Step 3
3	Repair the wiring harness between splice S204 and controller connector terminal A4 or between splice S204 and controller connector terminal A3. Is the repair complete?	-	System OK	-
4	Check the illumination lamps. Is one burned out?	-	Go to Step 5	Go to Step 6
5	Replace the burned out illumination lamp. Is the repair complete?	-	System OK	-
6	Replace the ATC controller. Is the repair complete?	-	System OK	-

### No Hot Air From Blower

Step	Action	Value(s)	Yes	No
1	Check the coolant level. Is the coolant level correct?	-	Go to Step 3	Go to Step 2
2	Add coolant as needed. Is the heater operating?	-	System OK	Go to Step 3
3	1. Turn the ignition to ON. 2. Observe the temperature indication screen of the controller.  Does the digit flash on and off?	-	Go to Step 4	Go to Step 5
4	Run a self-diagnosis circuit check. Does the display indicate a defect code?	-	Go to the table for the code that flashes	Go to Step 7
5	Observe the blower motor operation. Is the blower motor functioning at all?	-	Go to Step 6	Go to <a href="#">"Blower Motor Does Not Run at All"</a>
6	Use the blower push switch to cycle the blower through its different speeds. Does the motor function at different speeds?	-	Go to Step 7	Go to <a href="#">"Code 6 - Power Transistor Error"</a>
7	1. Run the blower and operate the MODE push switch manually. 2. Check for airflow out the various outlets.  Does the air flow from the different outlets as it should?	-	Go to Step 9	Go to Step 8
8	1. Remove the heater outlet and check for obstructions. 2. Remove any obstructions found.  Is the heater operating?	-	System OK	Go to Step 9
9	Observe the air mix door (AMD) motor while changing the temperature setting from 18 to 32°C (64 to 90°F) and then from 32 to 18°C (90 to 64°F). Is the AMD motor functioning properly?	-	Go to Step 10	Go to <a href="#">"Code 4 - Air Mix Door Error"</a>
10	Check the coolant hoses for leaks or kinks. Are the coolant hoses in good condition?	-	Go to Step 12	Go to Step 11
11	Repair any problem with the coolant hoses. Is the heater operating?	-	System OK	Go to Step 12
12	Check the surge tank cap. Is the surge tank cap in good condition?	-	Go to Step 14	Go to Step 13
13	Repair or replace the surge tank cap as needed. Is the heater operating?	-	System OK	Go to Step 14

Step	Action	Value(s)	Yes	No
14	<ol style="list-style-type: none"> <li>1. Set the A/C switch to OFF.</li> <li>2. Set the temperature control to 32°C (90°F).</li> <li>3. Set the blower motor speed to full high (all segments illuminated on the display).</li> <li>4. Remove the surge tank cap.</li> <li>5. Start the vehicle and run the engine at idle.</li> <li>6. Watch for the flow of the coolant when the thermostat opens.</li> </ol> <p>Does the coolant flow?</p>	-	Go to Step 16	Go to Step 15
15	<ol style="list-style-type: none"> <li>1. Check for <ul style="list-style-type: none"> <li>◦ A faulty thermostat.</li> <li>◦ A failed coolant pump impeller.</li> <li>◦ A restriction in the cooling system.</li> </ul> </li> <li>2. Make repairs as needed.</li> </ol> <p>Is the repair complete?</p>	-	System OK	-
16	<p>Check the temperature of the heater inlet and outlet hoses by feel.</p> <p>Is the heater inlet hose hot and the outlet hose warm?</p>	-	Go to Step 18	Go to Step 17
17	<p>Back flush or replace the heater core.</p> <p>Is the repair complete?</p>	-	System OK	-
18	<p>Check the vehicle for cold air leaks at the</p> <ul style="list-style-type: none"> <li>• Dash.</li> <li>• Heater cases.</li> <li>• Vents.</li> </ul> <p>Are any leaks found?</p>	-	Go to Step 20	Go to Step 19
19	<p>Repair any cold air leaks.</p> <p>Is the repair complete?</p>	-	System OK	-
20	<p>Check the coolant temperature sensor using the tests in <a href="#">"Code 3 - Coolant Temperature Sensor Error."</a></p> <p>Is there a problem indicated in the sensor, the sensor wiring, or the controller?</p>	-	Go to Step 21	Go to Step 22
21	<p>Repair or replace the sensor, the wiring, or the controller as required.</p> <p>Is the repair complete?</p>	-	System OK	-
22	<p>Check the in-car sensor using the tests in <a href="#">"Code 1 -In-Car Sensor Error."</a></p> <p>Is there a problem indicated in the sensor, the sensor wiring, or the controller?</p>	-	Go to Step 23	Go to Step 24
23	<p>Repair or replace the sensor, the wiring, or the controller as required.</p> <p>Is the repair complete?</p>	-	System OK	-
24	<p>Check the ambient air temperature sensor using the tests in <a href="#">"Code 2 - Ambient Air Temperature Sensor Error."</a></p> <p>Is there a problem indicated in the sensor, the sensor wiring, or the controller?</p>	-	Go to Step 25	Go to Step 26
25	<p>Repair or replace the sensor, the wiring, or the controller as required.</p> <p>Is the repair complete?</p>	-	System OK	-
26	<p>Check the sun sensor using the tests in <a href="#">"Code 5 - Sun Sensor Error."</a></p> <p>Is there a problem indicated in the sensor, the sensor wiring, or the controller?</p>	-	Go to Step 27	Go to Step 28
27	<p>Repair or replace the sensor, the wiring, or the controller as required.</p> <p>Is the repair complete?</p>	-	System OK	-
28	<p>Replace the ATC controller.</p> <p>Is the repair complete?</p>	-	System OK	-

#### No Cool Air From Blower

Step	Action	Value(s)	Yes	No
1	<ol style="list-style-type: none"> <li>1. Turn the ignition to ON.</li> <li>2. Observe the temperature indication screen of the controller.</li> </ol> <p>Does the digit flash on and off?</p>	-	Go to Step 2	Go to Step 3

Step	Action	Value(s)	Yes	No
2	Run a self-diagnosis circuit check. Does the display indicate a defect code?	-	Go to the table for the code that flashes.	Go to <i>Step 7</i>
3	Observe the blower motor operation. Is the blower motor functioning at all?	-	Go to <i>Step 4</i>	Go to " <a href="#">Blower Motor Does Not Run at All</a> "
4	Use the blower push switch to cycle the blower through its different speeds. Does the motor function at different speeds?	-	Go to <i>Step 5</i>	Go to " <a href="#">Code 6 - Power Transistor Error</a> "
5	1. Run the blower and operate the MODE push switch manually. 2. Check for airflow out the various outlets.  Does the air flow from the different outlets as it should?	-	Go to <i>Step 7</i>	Go to <i>Step 6</i>
6	1. Remove the heater outlet and check for obstructions. 2. Remove any obstructions found.  Is the heater operating?	-	System OK	Go to <i>Step 9</i>
7	Observe the air mix door motor (AMD) while changing the temperature setting from 18 to 32°C (64 to 90°F) and then from 32 to 18°C (90 to 64°F). Is the AMD motor functioning properly?	-	Go to <i>Step 8</i>	Go to " <a href="#">Code 3 - Air Mix Door Error</a> "
8	Perform the checks found in " <a href="#">Insufficient Cooling Diagnosis</a> ." Is the system operating normally now?	-	System OK	Go to <i>Step 9</i>
9	Place the controller in the AUTO mode. Is smoke taken into the intake port of the in-car sensor?	-	Go to <i>Step 12</i>	Go to <i>Step 10</i>
10	Check the intake hose for the in-car sensor. Is the hose in good condition?	-	Go to <i>Step 12</i>	Go to <i>Step 11</i>
11	Repair or replace the intake hose. Is the repair complete?	-	System OK	-
12	Check the in-car sensor using the tests in " <a href="#">Code 1 - In-Car Sensor Error</a> ." Is there a problem indicated in the sensor, the sensor wiring, or the controller?	-	Go to <i>Step 13</i>	Go to <i>Step 14</i>
13	Repair or replace the sensor, the wiring, or the controller as required. Is the repair complete?	-	System OK	-
14	Check the ambient air temperature sensor using the tests in " <a href="#">Code 2 - Ambient Air Temperature Sensor Error</a> ." Is there a problem indicated in the sensor, the sensor wiring, or the controller?	-	Go to <i>Step 15</i>	Go to <i>Step 16</i>
15	Repair or replace the sensor, the wiring, or the controller, as required. Is the repair complete?	-	System OK	-
16	Check the sun sensor using the tests in " <a href="#">Code 5 - Sun Sensor Error</a> ." Is there a problem indicated in the sensor, the sensor wiring, or the controller?	-	Go to <i>Step 17</i>	Go to <i>Step 18</i>
17	Repair or replace the sensor, the wiring, or the controller as required. Is the repair complete?	-	System OK	-
18	Perform the coolant temperature sensor test. Is the coolant temperature sensor malfunctioning?	-	Go to <i>Step 19</i>	Go to <i>Step 20</i>
19	Replace the coolant temperature sensor. Is the repair complete?	-	System OK	-
20	Replace the ATC controller. Is the repair complete?	-	System OK	-

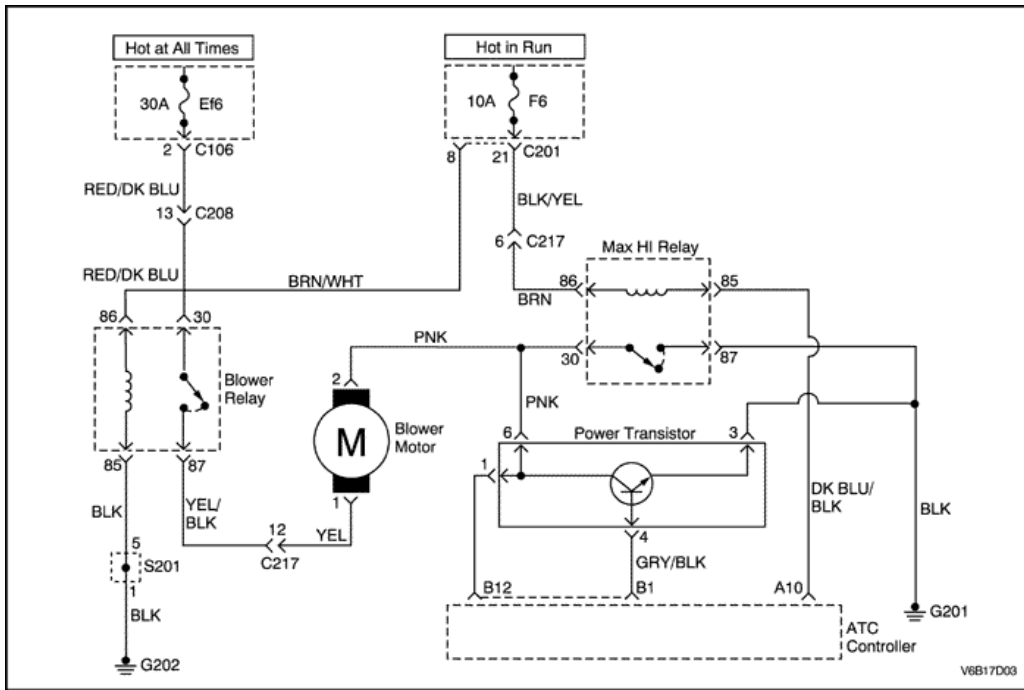

### Blower Motor Does Not Run At All

Step	Action	Value(s)	Yes	No
1	1. Turn the ignition to ON. 2. Observe the temperature indication screen of the controller.  Does the digit go on and off?	-	Go to Step 2	Go to Step 3
2	Run a self-diagnosis circuit check. Does the display indicate a defect code?	-	Go to the table for the code that flashes.	-
3	Check fuse F6 in the I/P fuse block. Is this fuse in good condition?	-	Go to Step 5	Go to Step 4
4	Replace fuse F6. Is the repair complete?	-	System OK	-
5	Check fuse EF6 in the engine fuse block. Is this fuse in good condition?	-	Go to Step 7	Go to Step 6
6	Replace fuse EF6. Is the repair complete?	-	System OK	-
7	1. Turn the ignition switch to ON. 2. Measure the voltage between ground and terminal 87(YEL/BLK) of the blower relay.  Is the voltage within the specified value?	11-14 v	Go to Step 15	Go to Step 8
8	Measure the voltage between ground and terminal 86 (BLK) at the blower relay. Is the voltage within the specified value?	11-14 v	Go to Step 10	Go to Step 9
9	1. Turn the ignition switch to OFF. 2. Check circuit BRN/WHT between terminal 86 of the blower relay to F6 in the I/P fuse block. 3. Repair any problem found in the wiring or terminals at the relay socket or connector C201.  Is the repair complete?	-	System OK	-
10	Measure the voltage between ground and terminal 30 (RED/DK BLU) at the blower relay. Is the voltage within the specified value?	11-14 v	Go to Step 12	Go to Step 11
11	1. Turn the ignition switch to OFF. 2. Check circuit RED/DK BLU between terminal 30 of the blower relay to EF6 in the engine fuse block. 3. Repair any problem found in the wiring or terminals at the fuse block connector C106, connector C208, or at the relay socket.  Is the repair complete?	-	System OK	-

Step	Action	Value(s)	Yes	No
12	1. Turn the ignition switch to OFF. 2. Check the continuity in the wiring harness between the blower relay terminal 85 (BLK) and ground.  Does the ohmmeter show the specified value?	$\approx 0 \Omega$	Go to Step 14	Go to Step 13
13	Repair any problem found in terminal 85 at the relay connector, circuit BLK, splice S201, or ground G202. Is the repair complete?	-	System OK	-
14	Replace the blower relay. Is the repair complete?	-	System OK	-
15	1. Turn the ignition switch to OFF. 2. Disconnect the wiring harness at the blower motor. 3. Turn the ignition switch to ON. 4. Measure voltage between ground and blower connector 1 (YEL).  Is the voltage within the specified value?	11-14 v	Go to Step 17	Go to Step 16
16	1. Turn the ignition switch to OFF. 2. Check circuit YEL between blower connector terminal 1 and blower relay terminal 87. 3. Repair any problem found in the wiring or a connector terminal at the blower connector, connector C217, or the blower relay socket.  Is the repair complete?	-	System OK	-
17	Measure the resistance between the connector terminals on the blower motor. Does the resistance match the specified value?	$\approx 5 \Omega$	Go to Step 19	Go to Step 18
18	Replace the blower motor. Is the repair complete?	-	System OK	-
19	Measure the resistance of circuit PNK between terminal 2 of the blower connector and terminal 30 of the Max HI relay and terminal 6 of the power transistor. Does the resistance match the specified value?	$\approx 0 \Omega$	Go to Step 21	Go to Step 20
20	Repair the problem in circuit PNK. Is the repair complete?	-	System OK	-
21	Measure the resistance of circuit BLK from terminal 3 of the power transistor connector to ground. Does the resistance match the specified value?	$\approx 0 \Omega$	Go to Step 23	Go to Step 22
22	1. Trace circuit BLK from terminal 3 of the power transistor connector and terminal 87 of the Max HI relay to ground G205. 2. Repair any problem found in the wiring, ground G205.  Is the repair complete?	-	System OK	-
23	Replace the ATC controller. the repair complete?	-	System OK	-

### Mode Control Do Not Work

Refer to ["A/C Blower and Motor Controls Diagram"](#) for the electrical schematic diagram of the circuits described in this procedure.

### Mode Controls Do Not Work

Step	Action	Value(s)	Yes	No
1	Measure the voltage between terminal 4 and ground of the mode motor and the HTR/DEF motor. Is the voltage within the specified value for both motors?	11-14 v	Go to Step 3	Go to Step 2
2	1. Check the connector and circuit BRN for any wiring or terminal problems. 2. Repair any problems found.  Is the repair complete?	-	System OK	-
3	1. Using the Motor Control Table, measure the voltages at the specified terminals of the specified motor connectors. 2. Change the mode settings and observe the voltage changes.  Are the voltages as specified?	See the "Motor Control Table"	Go to Step 4	Go to Step 5
4	Replace the motor that does not operate properly. Is the repair complete?	-	System OK	-

Step	Action	Value(s)	Yes	No
5	1. Using the Motor Control Table, measure the voltages at the specified terminals of the specified controller connectors. 2. Change the mode settings and observe the voltage changes.  Are the voltages as specified?	See the "Motor Control Table"	Go to Step 6	Go to Step 7
6	1. Check the wiring harness and connectors between the controller and the motor that is not performing properly. 2. Repair or replace the wiring harness or the defective terminal.  Is the repair complete?	-	System OK	-
7	Check the connector at the controller. Is there a defective terminal?	-	Go to Step 8	Go to Step 9
8	Repair or replace the terminal. Is the repair complete?	-	System OK	-
9	Replace the controller. Is the repair complete?	-	System OK	-

### Motor Control Table

Mode Setting	Mode Motor			HTR/DEF Motor		
	Connector Terminal					
	Controller/ Motor	Controller/ Motor	Controller/ Motor	Controller/ Motor	Controller/ Motor	Controller/ Motor
	B20/3	B19/2	B18/1	B17/2	B16/1	B15/7
Vent	11-14 v	11-14 v	0 v	0 v	11-14 v	11-14 v
Bi-Level	11-14 v	0 v	11-14 v	11-14 v	11-14 v	0 v
Foot	0 v	11-14 v	11-14 v	11-14 v	11-14 v	0 v
Foot/Defrost	0 v	11-14 v	11-14 v	0 v	11-14 v	11-14 v
Defrost	0 v	11-14 v	11-14 v	0 v	11-14 v	11-14 v

### Air Source Selection Not Controlled

Refer to ["A/C Blower and Motor Controls Diagram"](#) for the electrical schematic diagram of the circuits described in this procedure.

### Air Source Selection Not Controlled

Step	Action	Value(s)	Yes	No
1	Measure the voltage at terminal 4 of the intake motor. Is the voltage within the value specified?	11-14 v	Go to Step 3	Go to Step 2
2	1. Check the connector and circuit BRN for any wiring or terminal problems. 2. Repair any problems found.  Is the repair complete?	-	System OK	-
3	1. Using the Intake Motor Table, measure the voltages at the specified terminals of the motor connector. 2. Change the intake setting and observe the voltage changes.  Are these voltages within the specified value?	See the "Intake Motor Table"	Go to Step 4	Go to Step 5
4	Replace the intake motor. Is the repair complete?	-	System OK	-
5	1. Using the Intake Motor Table, measure the voltages at the specified terminals of the controller connector. 2. Change the intake setting and observe the voltage changes.  Are these voltages within the specified value?	See the "Intake Motor Table"	Go to Step 6	Go to Step 7
6	1. Check the wiring harness and connectors between the controller and the motor that is not performing properly. 2. Repair or replace the wiring harness or the defective terminal.  Is the repair complete?	-	System OK	-
7	Check the connector at the controller. Is there a defective terminal?	-	Go to Step 8	Go to Step 9
8	Repair or replace the terminal. Is the repair complete?	-	System OK	-

Step	Action	Value(s)	Yes	No
9	Replace the controller. Is the repair complete?	-	System OK	-

### Intake Control Table

Intake Setting	Intake Motor		
	Connector Terminal		
	Controller/Motor	Controller/Motor	Controller/Motor
	<b>B14/7</b>	<b>A15/6</b>	<b>B13/5</b>
Recirculate	0 v	11-14 v	11-14 v
1/3 Fresh	11-14 v	0 v	11-14 v
Fresh	11-14 v	11-14 v	0 v

### Compressor Magnetic Clutch Does Not Engage

Refer to "A/C Compressor Controls, SOHC" or "A/C Compressor Controls, DOHC" for the electrical schematic diagram of the circuits described in this procedure.

### Compressor Magnetic Clutch Does not Engage

Step	Action	Value(s)	Yes	No
1	1. Remove the ATC Controller from the instrument panel, keeping the wiring harness connected. 2. Turn the ignition switch to ON. 3. Turn the A/C switch to ON. 4. Check the voltage between ground and terminal A11 on the controller.  Is the voltage within the specified value?	11-14 v	Go to <a href="#">"Insufficient Cooling Diagnosis"</a>	Go to Step 2
2	Replace the ATC controller. Is the repair complete?	-	System OK	-

### DIAGNOSTIC TROUBLE CODES

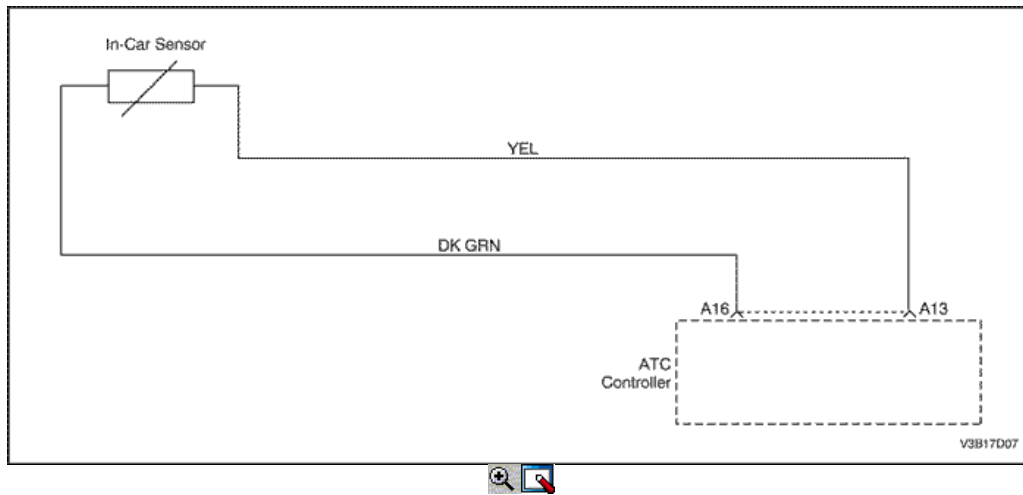

### Code 1 - In-Car Sensor Error

This code will set if the output of the in-car sensor indicates a probable short circuit or an open in the sensor or the associated wiring harness, or a malfunction of the ATC controller.

### Code 1 - In-Car Sensor Error

Step	Action	Value(s)	Yes	No

Step	Action	Value(s)	Yes	No
1	<ol style="list-style-type: none"> <li>1. Disconnect the in-car sensor connector from the ATC controller.</li> <li>2. Examine the wiring from the sensor to the connector and the connector for any signs of damage.</li> <li>3. Measure the resistance between the in-car sensor connector terminals.</li> </ol> <p>Is there any sign of damage in the wiring or connector, or is the resistance outside the specified value at 20 to 25°C (68 to 77°F)?</p>	2600-2100 Ω	Go to Step 2	Go to Step 3
2	<p>Repair the damaged wiring or the connector, or replace the in-car sensor as required.</p> <p>Is the repair complete?</p>	-	System OK	-
3	<ol style="list-style-type: none"> <li>1. Turn the ignition to ON.</li> <li>2. Measure the voltage between the two connector terminals on the controller housing.</li> </ol> <p>Is the voltage equal to the value specified?</p>	> 4 v	Go to Step 7	Go to Step 4
4	<p>Check the terminals on the in-car sensor connector.</p> <p>Is any problem found with the connector?</p>	-	Go to Step 5	Go to Step 6
5	<p>Repair the connector terminals or replace the in-car sensor or ATC controller as required.</p> <p>Is the repair complete?</p>	-	System OK	-
6	<ol style="list-style-type: none"> <li>1. Reconnect the in-car sensor to the controller.</li> <li>2. Turn the ignition switch to ON.</li> <li>3. Observe the temperature display area.</li> </ol> <p>Does this display indicate the continuing presence of a code 1 condition?</p>	-	Go to Step 7	System OK
7	<p>Replace the ATC controller.</p> <p>Is the repair complete?</p>	-	System OK	-

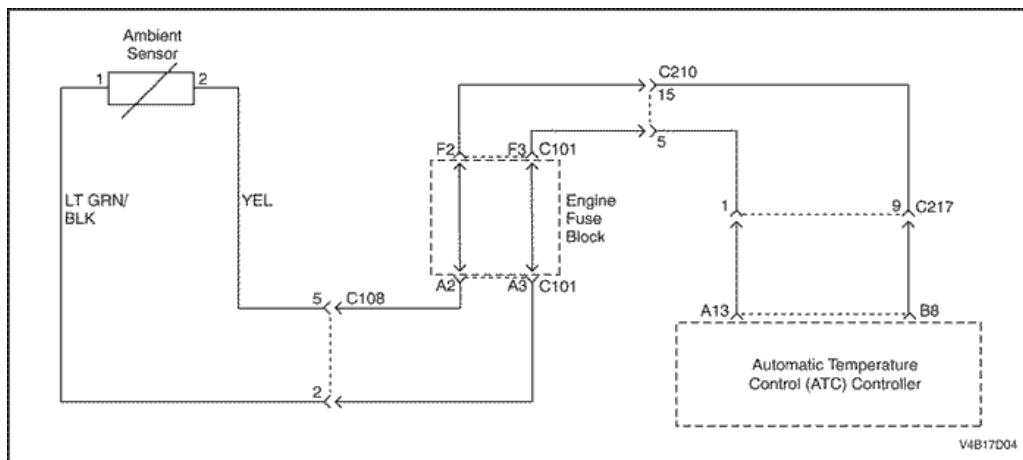

### Code 2 - Ambient Air Temperature Sensor Error

This code will set if the output of the ambient air temperature sensor indicates a probable short circuit or an open in the sensor or the associated wiring harness, or a malfunction of the ATC controller.

### Code 2 - Ambient Air Temperature Sensor Error

Step	Action	Value(s)	Yes	No
1	<ol style="list-style-type: none"> <li>1. Disconnect the ambient air sensor connector from the front bumper harness.</li> <li>2. Measure the resistance between the ambient air sensor connector terminals.</li> </ol> <p>Is the resistance equal to the specified value at 20 to 25°C (68 to 77°F)?</p>	2600-2100 Ω	Go to Step 5	Go to Step 2
2	<ol style="list-style-type: none"> <li>1. Remove the ambient air sensor from behind the front bumper.</li> <li>2. Examine the wiring for any open or short and examine the connector for any damage.</li> </ol> <p>Is there a problem with the wiring or the connector?</p>	-	Go to Step 3	Go to Step 4

Step	Action	Value(s)	Yes	No
3	Repair the problem found in the ambient air sensor wiring or the connector. Is the repair complete?	-	System OK	-
4	Replace the ambient air sensor. Is the repair complete?	-	System OK	-
5	1. Turn the ignition to ON. 2. Measure the voltage between the two terminals in the ambient air sensor connector on the front bumper harness.  Is the voltage equal to the value specified?	> 4 v	Go to Step 7	Go to Step 6
6	1. Reconnect the in-car sensor to the controller. 2. Turn the ignition switch to ON. 3. Observe the temperature display area.  Does this display indicate the continuing presence of a code 2 condition?	-	Go to Step 8	System OK
7	1. Pull the ATC controller from the instrument panel, leaving the wiring harness connected. 2. Measure the voltage between terminals A13 and B8 by backprobing the connectors.  Is the voltage equal to the value specified?	< 4 v	Go to Step 8	Go to Step 9
8	Replace the ATC Controller. Is the repair complete?	-	System OK	-
9	1. Trace the wiring for the ambient air sensor from the ATC controller, through connectors C217, C210 and C101 at the engine fuse block, and C108 to the ambient air sensor connector on the front bumper harness. 2. Repair any open or high resistance condition in the wiring or a connector terminal.  Is the repair complete?	-	System OK	-

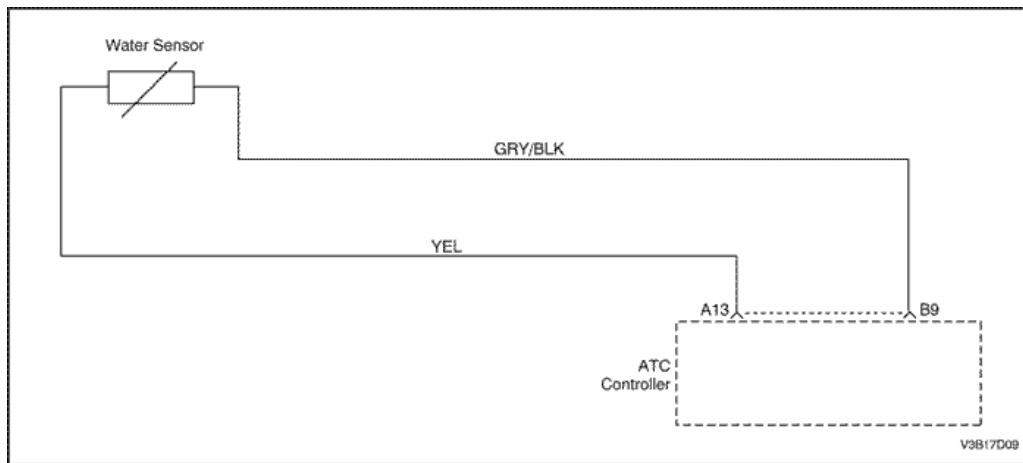

### Code 3 - Coolant Temperature Sensor Error

This code will set if the output of the coolant sensor indicates a probable short circuit or an open in the sensor or the associated wiring harness, or a malfunction of the ATC controller.

### Code 3 - Coolant Temperature Sensor Error

Step	Action	Value(s)	Yes	No
1	1. Disconnect the coolant temperature sensor connector from the ATC harness. 2. Examine the wiring from the sensor to the connector and examine the connector for any signs of damage. 3. Measure the resistance between the coolant temperature sensor connector terminals.  Is there any sign of damage in the wiring or the connector, or is the resistance outside the specified value at 20 to 25°C (68 to 77°F)?	2600-2100 Ω	Go to Step 2	Go to Step 3

Step	Action	Value(s)	Yes	No
2	Repair the damaged wiring or the connector, or replace the coolant temperature sensor as required. Is the repair complete?	-	System OK	-
3	1. Turn the ignition to ON. 2. Measure the voltage between the two coolant temperature sensor connector terminals on the ATC harness.  Is the voltage equal to the specified value?	< 4 v	Go to Step 7	Go to Step 4
4	Check the terminals on the coolant temperature sensor connector. Is any problem found with the connector?	-	Go to Step 5	Go to Step 6
5	Repair the connector terminals or replace the coolant temperature sensor or ATC controller as required. Is the repair complete?	-	System OK	-
6	1. Reconnect the coolant temperature sensor to the ATC harness. 2. Turn the ignition switch to ON. 3. Observe the temperature display area.  Does this display indicate the continuing presence of a code 3 condition?	-	Go to Step 9	System OK
7	1. Pull the ATC controller from the instrument panel, leaving the wiring harness connected. 2. Measure the voltage between terminals A13 and B9 by backprobing the connectors.  Is the voltage equal to the value specified?	< 4 v	Go to Step 9	Go to Step 8
8	1. Trace the wiring from controller terminals A13 and B9 to the coolant temperature sensor connector terminals on the ATC harness connectors. 2. Repair any open or high resistance found in the wiring or connector terminals.  Is the repair complete?	-	System OK	-
9	Replace the ATC controller. Is the repair complete?	-	System OK	-

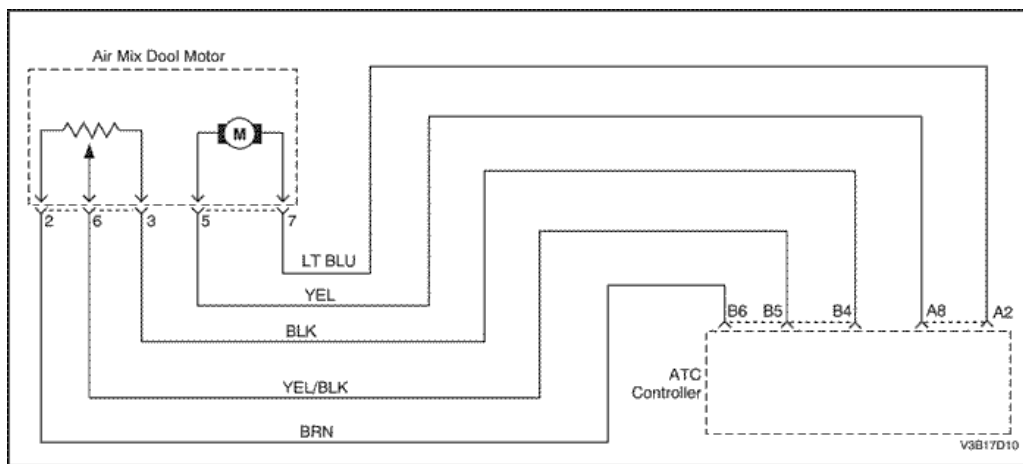

#### Code 4 - Air Mix Door Error

This code will set if the output of the mix door indicator indicates that the door opening angle is out of range or does not change value when the door should be moving. This would indicate a short circuit or an open in the sensor or the associated wiring harness, a door motor that is not operating, or a malfunction of the ATC controller.

#### Code 4 - Air Mix Door Error

Step	Action	Value(s)	Yes	No

Step	Action	Value(s)	Yes	No
1	<ol style="list-style-type: none"> <li>1. Disconnect the I/P wiring harness connector from the air mix door (AMD) motor.</li> <li>2. Use an ohmmeter to measure the resistance between terminals 5 and 7 on the AMD motor.</li> </ol> <p>Does the measured resistance indicate an open or a shorted condition?</p>	Open = $\infty$ , Short = $\approx 0 \Omega$	Go to Step 4	Go to Step 2
2	<p>Measure the resistance between terminals 2 and 3 on the AMD motor.</p> <p>Is the resistance equal to the value specified?</p>	$\approx 3000 \Omega$	Go to Step 3	Go to Step 4
3	<p>Measure the resistance between terminals 6 and 2 and between terminals 6 and 3 on the AMD motor.</p> <p>Do these resistances add to approximately the value measured between terminals 2 and 3?</p>	$\approx 3000 \Omega$	Go to Step 5	Go to Step 4
4	<p>Replace the AMD motor.</p> <p>Is the repair complete?</p>	-	System OK	-
5	<p>Check the connector terminals at the AMD motor and the wiring in the ATC harness.</p> <p>Is there a problem with any terminal on either the harness connector or the motor connector or the wiring?</p>	-	Go to Step 6	Go to Step 7
6	<p>Repair the problem found with a connector terminal or the wiring, or replace the motor as required.</p> <p>Is the repair complete?</p>	-	System OK	-
7	<ol style="list-style-type: none"> <li>1. Remove the ATC controller from the instrument panel.</li> <li>2. Disconnect the harness connectors from the ATC controller.</li> <li>3. Examine the connector terminals on the harness connectors and the controller connectors and the harness wiring.</li> </ol> <p>Is there a problem with any of these connectors or the wiring?</p>	-	Go to Step 8	Go to Step 9
8	<p>Repair the problem found with a connector terminal or wiring.</p> <p>Is the repair complete?</p>	-	System OK	-
9	<p>Check continuity in the harness between the controller connectors and the AMD motor connector.</p> <ul style="list-style-type: none"> <li>• Controller terminal A2 to motor terminal 7.</li> <li>• Controller terminal A8 to motor terminal 5.</li> <li>• Controller terminal B6 to motor terminal 2.</li> <li>• Controller terminal B5 to motor terminal 6.</li> <li>• Controller terminal B4 to motor terminal 3.</li> </ul> <p>Does the continuity equal the specified value?</p>	$\approx 0 \Omega$	Go to Step 10	Go to Step 11
10	<p>Repair the continuity problem.</p> <p>Is the repair complete?</p>	-	System OK	-
11	<ol style="list-style-type: none"> <li>1. Reconnect the AMD motor to the ATC harness.</li> <li>2. Reconnect the ATC harness connectors to the controller.</li> <li>3. Turn the ignition to ON.</li> <li>4. Use backprobing for voltage measurements.</li> <li>5. Measure the voltage between ground and terminal B5 at the controller.</li> </ol> <p>Is the voltage equal to the specified value?</p>	< 4 v	Go to Step 12	Go to Step 14
12	<ol style="list-style-type: none"> <li>1. Set the temperature controller to 18°C (64°F).</li> <li>2. Connect a voltmeter between ground and terminal A8 at the controller. It should display about 12 v.</li> <li>3. Raise the temperature setting on the controller to 32°C (90°F).</li> </ol> <p>Does the voltage equal the specified value?</p>	Drops from 12 v to 0 v	Go to Step 13	Go to Step 15
13	<ol style="list-style-type: none"> <li>1. Connect a voltmeter between ground and terminal A2 at the controller. It should display about 12 v.</li> <li>2. Change the temperature setting to 18°C (64°F).</li> </ol> <p>Does the voltage equal the specified value?</p>	Drops from 12 v to 0 v	Go to Step 20	Go to Step 15
14	<ol style="list-style-type: none"> <li>1. Recheck the wiring harness and the connector terminals associated with controller terminals B4, B5, and B6, and AMD motor terminals 2, 6, and 3.</li> <li>2. Repair any problem found.</li> </ol> <p>Is the repair complete?</p>	-	System OK	-

Step	Action	Value(s)	Yes	No
15	Recheck all wiring circuits between the controller and the AMD motor. Is there a problem in the wiring or the connectors?	-	Go to Step 16	Go to Step 17
16	Repair the problem in the wiring between the ATC controller and the AMD motor. Is the repair complete?	-	System OK	-
17	Recheck the AMD motor. Is there a problem in the AMD motor?	-	Go to Step 18	Go to Step 19
18	Replace the AMD motor. Is the repair complete?	-	System OK	-
19	Replace the controller. Is the repair complete?	-	System OK	-
20	Observe the operation of the air mix door when the temperature setting is changed. Does the door move normally?	-	Go to Step 22	Go to Step 21
21	Repair or replace the air mix door. Is the repair complete?	-	System OK	-
22	Observe the operation of the AMD motor when the temperature setting is changed. Does the motor operate normally?	-	Go to Step 24	Go to Step 23
23	Replace the AMD motor. Is the repair complete?	-	System OK	-
24	Reconnect everything and test the system. Does code 4 reset?	-	Go to Step 25	System OK
25	Replace the controller. Is the repair complete?	-	System OK	-

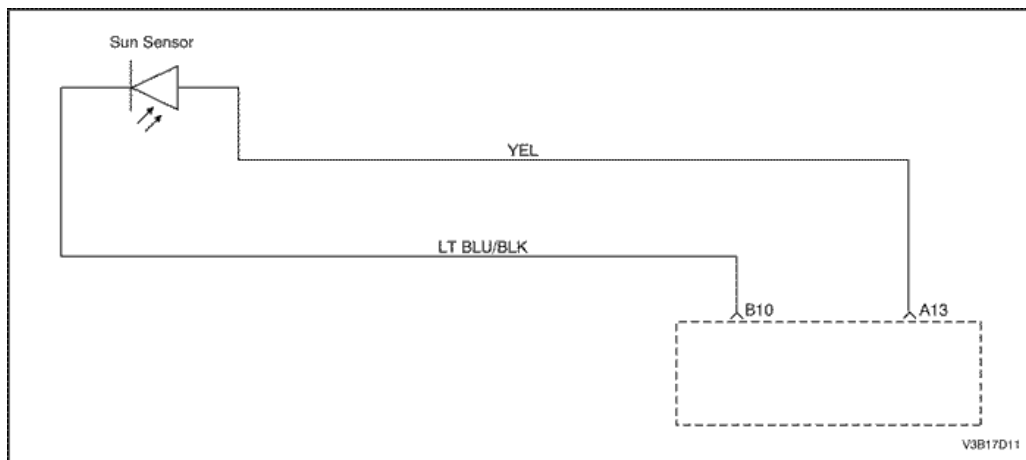

### Code 5 - Sun Sensor Error

This code will set if the output of the sun sensor indicates a probable short circuit or an open in the sensor or the associated wiring harness, or a malfunction of the ATC controller.

### Code 5 - Sun Sensor Error

Step	Action	Value(s)	Yes	No
1	<ol style="list-style-type: none"> <li>Lift the sun sensor from the top of the dashboard.</li> <li>Secure the ATC harness below the sun sensor connector so it cannot fall through the opening in the top of the dashboard.</li> <li>Disconnect the sun sensor connector from the ATC harness.</li> <li>Examine the wiring from the sensor to the connector, and examine the connector for any signs of damage.</li> <li>Measure the resistance between the sun sensor connector terminals.</li> </ol> <p>Is there any sign of damage in the wiring or connector or does the resistance equal the value specified?</p>	≈ 0 Ω	Go to Step 2	Go to Step 3



Step	Action	Value(s)	Yes	No
1	1. Disconnect the ATC controller connectors A and B. 2. Disconnect the connectors from the power transistor. 3. Measure the resistance circuit GRY/BLK from terminal 4 of the power transistor to terminal B1 of the ATC controller.  Does the resistance equal the specified value?	$\approx 0 \Omega$	Go to Step 2	Go to Step 6
2	Measure the resistance in the circuit from terminal 1 of the power module control unit to terminal B12 of the ATC controller. Does the resistance equal the specified value?	$\approx 0 \Omega$	Go to Step 3	Go to Step 6
3	1. Reconnect the wiring harness to the ATC controller and to the power module control unit. 2. Turn the ignition switch to ON. 3. Measure the voltage from ground to terminal B12 of the ATC controller. 4. Cycle the fan speed controller manually from the lowest (speed 1) to the highest speed (5).  Do the voltages measured match approximately the specified values within $\pm 0.5$ v?	1: 8.8 v 2: 6.8 v 3: 4.4 v 4: 2.7 v 5: 0 v	Go to Step 4	Go to Step 5
4	Replace the ATC controller. Is the repair complete?	-	System OK	-
5	Measure the resistance in circuit PNK between terminal 6 of the power transistor and the blower motor terminal 2. Does the resistance equal the specified value?	$\approx 0 \Omega$	Go to Step 7	Go to Step 6
6	Repair or replace the wiring harness for the circuit PNK. Is the repair complete?	-	System OK	-
7	Check the wiring harness of the motor and power supply.  • Check the blower relay. • Check fuse EF6.  Is there any problem in the wiring, the relay, or the fuse?	-	Go to Step 9	Go to Step 8
8	Replace the power transistor. Is the repair complete?	-	System OK	-
9	Repair or replace the wiring harness, the relay, or the fuse as required. Is the repair complete?	-	System OK	-

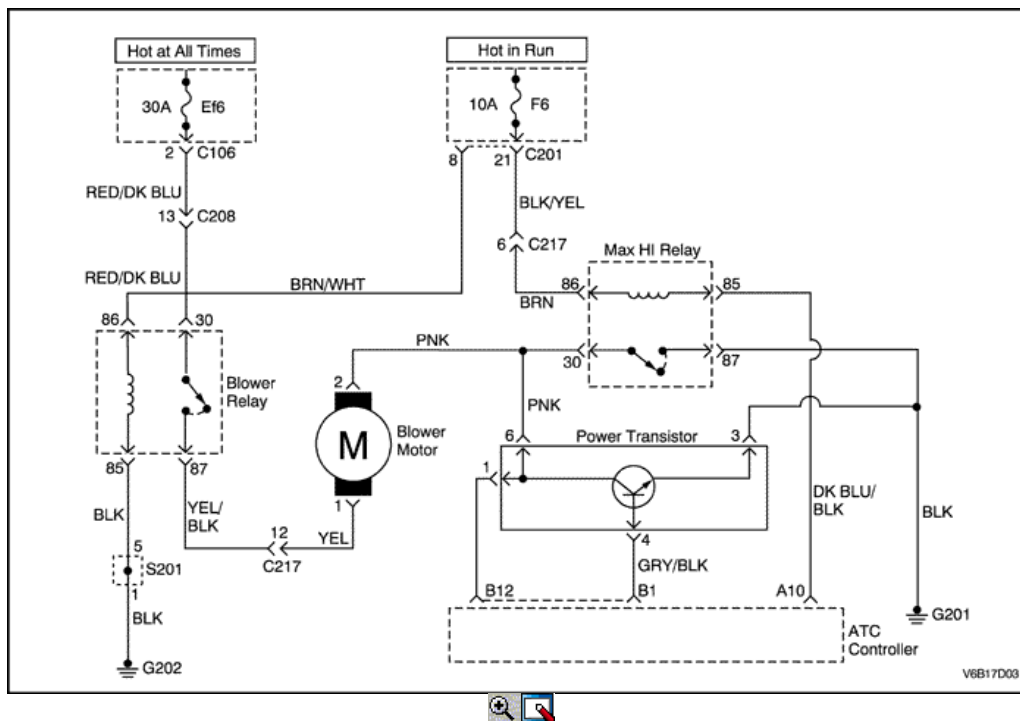

### Code 7 - Max-Hi Relay Error

Step	Action	Value(s)	Yes	No

Step	Action	Value(s)	Yes	No
1	1. Turn the ignition switch ON. 2. Set the blower speed manually for 5th speed. 3. Measure voltage between the ATC controller terminal A10 and ground.  Is the voltage approximately equal to the specified value?	$\approx 0 \Omega$	Go to <i>Step 3</i>	Go to <i>Step 2</i>
2	Replace the ATC controller. Is the repair complete?	-	System OK	-
3	1. Check the wiring harness associated with the MAX-HI relay for defects or high terminal resistance. 2. Repair any defects found.  Is the repair complete?	-	System OK	Go to <i>Step 4</i>
4	Replace the MAX-HI relay. Is the repair complete?	-	System OK	-



© Copyright Chevrolet Europe. All rights reserved